4.25 Gbps Cable and PC Board Equalizer

FEATURES

- Multi-Rate Operation Up To 4.25 Gbps
- Compensates Up To 12 dB Loss At 2.1 GHz
- Suitable To Receive 4.25-Gbps Data Over Up To 30 Inches (0,76 Meters) Of FR4 PC Boards
- Suitable To Receive 4.25-Gbps Data Over Up To 30 Feet (9,1 Meters) Of CX4 Cable
- Ultra-Low Power Consumption
- Input Offset Cancellation
- High Input Dynamic Range
- Output Disable
- Output Polarity Select
- CML Data Outputs
- Single 3.3-V Supply
- Surface Mount Small Footprint 3 mm × 3 mm 16-Pin QFN Package

APPLICATIONS

- 1.0625 Gbps, 2.125 Gbps, and 4.25 Gbps Fibre Channel Systems
- High Speed Links In Communication and Data Systems
- Backplane Interconnect
- Rack-to-Rack Interconnect

DESCRIPTION

The TLK4211EA is a versatile high-speed limiting equalizer for applications in digital high-speed links with data rates up to 4.25 Gbps.

This device provides a high frequency boost of 12 dB at 2.1 GHz as well as sufficient gain to ensure a fully differential output swing for input signals as low as 200 mVp-p (at the input of the interconnect line).

The high input signal dynamic range ensures low jitter output signals even when overdriven with input signal swings as high as 2000 mVp-p.

The TLK4211EA is available in a small footprint 3 mm × 3 mm 16-pin QFN package. It requires a single 3.3-V supply.

This power efficient equalizer is characterized for operation from –40°C to 85°C.



Please be aware that an important notice concerning availability, standard warranty, and use in critical applications of Texas Instruments semiconductor products and disclaimers thereto appears at the end of this data sheet.

BLOCK DIAGRAM

A simplified block diagram of the TLK4211EA is shown in [Figure 1](#).

This compact, low-power 4.25-Gbps equalizer consists of a high-speed data path with offset cancellation circuitry, a bandgap voltage reference, and bias current generation block.

The equalizer requires a single 3.3-V supply voltage. All circuit parts are described in detail in below.

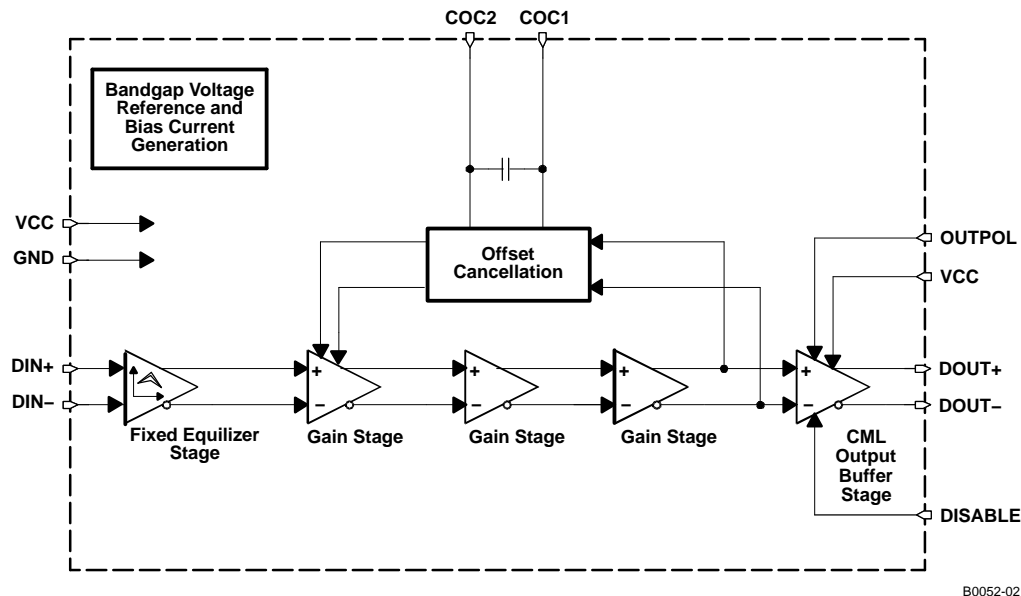

Figure 1. Simplified Block Diagram of the TLK4211EA

HIGH-SPEED DATA PATH

The high-speed data signal with frequency dependent loss is applied to the data path by means of the input signal pins DIN+/DIN-. The data path consists of the fixed equalizer input stage with 100-Ω differential on-chip line termination, three gain stages, which provide the required gain to ensure a limited output signal, and a CML output stage. The equalized and amplified data output signal is available at the output pins DOUT+/DOUT-, which provide $2 \times 50\text{-}\Omega$ back-termination to VCC. The output stage also includes a data polarity switching function, which is controlled by the OUTPOL input, and a disable function controlled by the signal applied to the DISABLE input pin.

An offset cancellation compensates inevitable internal offset voltages and thus ensures proper operation even for small input data signals.

The low frequency cutoff is as low as 10 kHz with the built-in filter capacitor.

For applications which require even lower cutoff frequencies, an additional external filter capacitor may be connected to the COC1/COC2 pins.

BANDGAP VOLTAGE AND BIAS GENERATION

The TLK4211EA equalizer is supplied by a single 3.3-V $\pm 10\%$ supply voltage connected to the VCC pins. This voltage is referred to ground (GND).

An on-chip bandgap voltage circuitry generates a supply voltage independent reference from which all other internally required voltages and bias currents are derived.

PACKAGE

The TLK4211EA is available in a small footprint 3 mm \times 3 mm, 16-pin QFN package with a lead pitch of 0,5 mm. The pin out is shown below in [Figure 2](#).

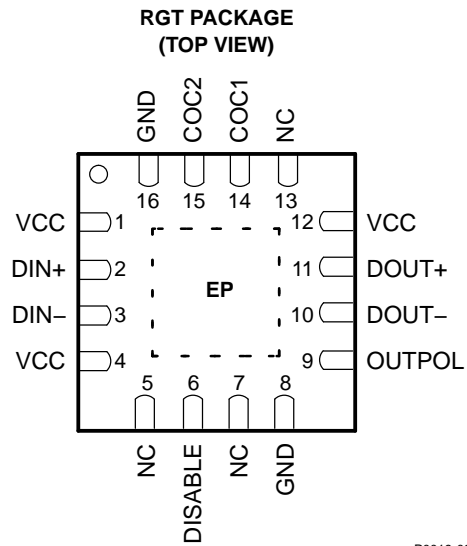

Figure 2. Pin Out of TLK4211EA in a 3 mm × 3 mm 16-Pin QFN Package

TERMINAL FUNCTIONS

TERMINAL		TYPE	DESCRIPTION
NAME	NO.		
VCC	1, 4, 12	Supply	3.3-V ±10% supply voltage
DIN+	2	Analog in	Non-inverted data input. On-chip 100-Ω terminated to DIN–
DIN–	3	Analog in	Inverted data input. On-chip 100-Ω terminated to DIN+
NC	5, 7, 13		Not connected
DISABLE	6	CMOS in	Disables CML output stage when set to high level
GND	8, 16	Supply	Circuit ground.
OUTPUTPOL	9	CMOS in	Output data signal polarity select (internally pulled up): Setting to high-level or leaving pin open selects normal polarity. Low-level selects inverted polarity.
DOUT–	10	CML out	Inverted data output. On-chip 50-Ω back-terminated to VCC.
DOUT+	11	CML out	Non-inverted data output. On-chip 50-Ω back-terminated to VCC.
COC1	14	Analog	Offset cancellation filter capacitor terminal 1. Connect an additional filter capacitor between this pin and COC2 (pin 15). To disable the offset cancellation loop connect COC1 and COC2 (pins 14 and 15).
COC2	15	Analog	Offset cancellation filter capacitor terminal 2. Connect an additional filter capacitor between this pin and COC1 (pin 14). To disable the offset cancellation loop connect COC1 and COC2 (pins 14 and 15).
EP	EP		Exposed die pad (EP) must be grounded.

ABSOLUTE MAXIMUM RATINGS

over operating free-air temperature range (unless otherwise noted)⁽¹⁾

		VALUE / UNIT
V _{CC}	Supply voltage ⁽²⁾	–0.3 V to 4 V
V _{DIN+} , V _{DIN–}	Voltage at DIN+, DIN– ⁽²⁾	0.5 V to 4 V
V _{DISABLE} , V _{OUTPOL} , V _{DOUT+} , V _{DOUT–} , V _{COC1} , V _{COC2}	Voltage at DISABLE, OUTPOL, DOUT+, DOUT–, COC1, COC2 ⁽²⁾	–0.3 V to 4 V
V _{COC,DIFF}	Differential voltage between COC1 and COC2	±1 V
V _{DIN,DIFF}	Differential voltage between DIN+ and DIN–	±2.5 V
I _{DIN+} , I _{DIN–} , I _{DOUT+} , I _{DOUT–}	Continuous current at inputs and outputs	– 25 mA to 25 mA
ESD	ESD rating at all pins	2.5 kV (HBM)
T _{J(max)}	Maximum junction temperature	125°C
T _{STG}	Storage temperature range	–65°C to 85°C
T _A	Characterized free-air operating temperature range	–40°C to 85°C
T _L	Lead temperature 1,6 mm (1/16 inch) from case for 10 seconds	260°C

- (1) Stresses beyond those listed under *absolute maximum ratings* may cause permanent damage to the device. These are stress ratings only, and functional operation of the device at these or any other conditions beyond those indicated under *recommended operating conditions* is not implied. Exposure to absolute–maximum–rated conditions for extended periods may affect device reliability.
- (2) All voltage values are with respect to network ground terminal.

RECOMMENDED OPERATING CONDITIONS

		MIN	NOM	MAX	UNIT
V _{CC}	Supply voltage	3	3.3	3.6	V
T _A	Operating free-air temperature	–40		85	°C
	CMOS input high voltage	2.1			V
	CMOS input low voltage			0.6	V

DC ELECTRICAL CHARACTERISTICS

over recommended operating conditions, typical operating condition is at V_{CC} = 3.3 V and T_A = 25°C (unless otherwise noted)

PARAMETER	TEST CONDITIONS	MIN	TYP	MAX	UNIT
V _{CC}	Supply voltage	3	3.3	3.6	V
I _{CC}	Supply current DISABLE = low, including CML output current		30	38	mA
R _{IN}	Data input resistance Differential		100		Ω
R _{OUT}	Data output resistance Single-ended to VCC		50		Ω

AC ELECTRICAL CHARACTERISTICS

over recommended operating conditions, typical operating condition is at V_{CC} = 3.3 V and T_A = 25°C (unless otherwise noted)

PARAMETER	TEST CONDITIONS	MIN	TYP	MAX	UNIT
Low frequency –3 dB bandwidth	C _{OC} = open		10	50	kHz
	C _{OC} = 0.22 μF		0.8		
Data rate		4.25			Gbps
V _{IN,MIN}	Data input sensitivity ⁽¹⁾ BER < 10 ^{–12} , voltage at the input of the interconnect line		200	250	mV _{p-p}
V _{IN,MAX}	Data input overload Voltage at the input of the interconnect line	2000			mV _{p-p}
High frequency boost	f = 2.1 GHz		12		dB
V _{OD}	Differential data output voltage swing DISABLE = high		0.25	10	mV _{p-p}
	DISABLE = low	580	780	1200	

- (1) The given differential input signal swing is measured at the input of the interconnect line. The high frequency components of the signal at the output of the interconnect line (which is connected the input pins DIN+/DIN– of the TLK4211EA) may be attenuated by 0 dB up to 12 dB at 2.1 GHz dependent of the interconnect line length.

AC ELECTRICAL CHARACTERISTICS (continued)

 over recommended operating conditions, typical operating condition is at $V_{CC} = 3.3\text{ V}$ and $T_A = 25^\circ\text{C}$ (unless otherwise noted)

PARAMETER		TEST CONDITIONS	MIN	TYP	MAX	UNIT
DJ	Deterministic jitter, 4.25 Gbps, K28.5 pattern, $V_{IN} = 200\text{ mVpp}$ (differential voltage at the cable input)	No board or cable		20		ps_{p-p}
		12 inches of 7 mils wide microstrip interconnect line on standard FR4		30		
		24 inches of 7 mils wide microstrip interconnect line on standard FR4		30		
		36 inches of 7 mils wide microstrip interconnect line on standard FR4		30		
		30 feet CX4 cable		20		
	Deterministic jitter, 3.3 Gbps, K28.5 pattern, $V_{IN} = 200\text{ mVpp}$ (differential voltage at the cable input)	No board or cable		20		ps_{p-p}
		48 inches of 7 mils wide microstrip interconnect line on standard FR4		25		
		30 feet CX4 cable		20		
RJ	Random jitter	Input = 200 mV_{p-p} , 36 inches of 7 mils wide stripline interconnect line on standard FR4 (voltage at the input of the interconnect line)		4.5		ps_{RMS}
	Latency	From $\text{DIN}\pm$ to $\text{DOUT}\pm$		250		ps
t_r	Output rise time	20% to 80%, without microstrip line loss at input		55	85	ps
t_f	Output fall time	20% to 80%, without microstrip line loss at input		55	85	ps
T_{DIS}	Disable response time			20		ns

APPLICATION INFORMATION

Figure 3 shows the TLK4211EA connected with an ac-coupled interface to the data signal source via a microstrip interconnect line. The output load is ac-coupled as well.

The ac coupling capacitors C_1 through C_4 in the input and output data signal lines are the only required external components. In addition, if a low cutoff frequency is required, as an option, an external filter capacitor C_{OC} may be used.

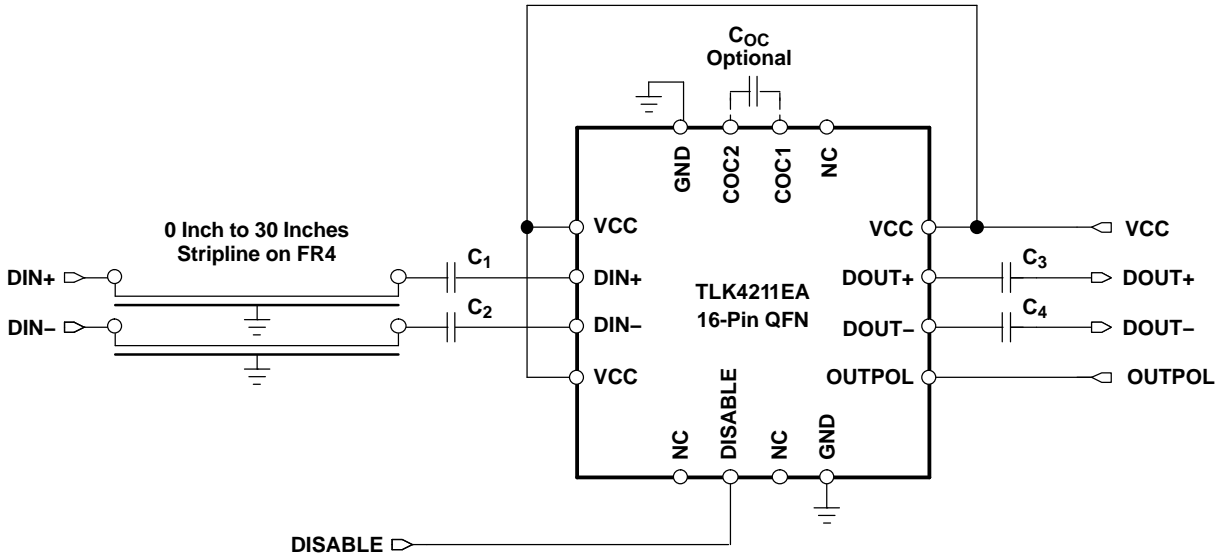

S0072-02

Figure 3. Basic Application Circuit With AC Coupled I/Os

TYPICAL CHARACTERISTICS

Typical operating condition is at $V_{CC} = 3.3\text{ V}$ and $T_A = 25^\circ\text{C}$ (unless otherwise noted).

DIFFERENTIAL EQUALIZER INPUT SIGNAL (TOP) AND OUTPUT SIGNAL (BOTTOM) AT 4.25 GBPS USING A K28.5 PATTERN

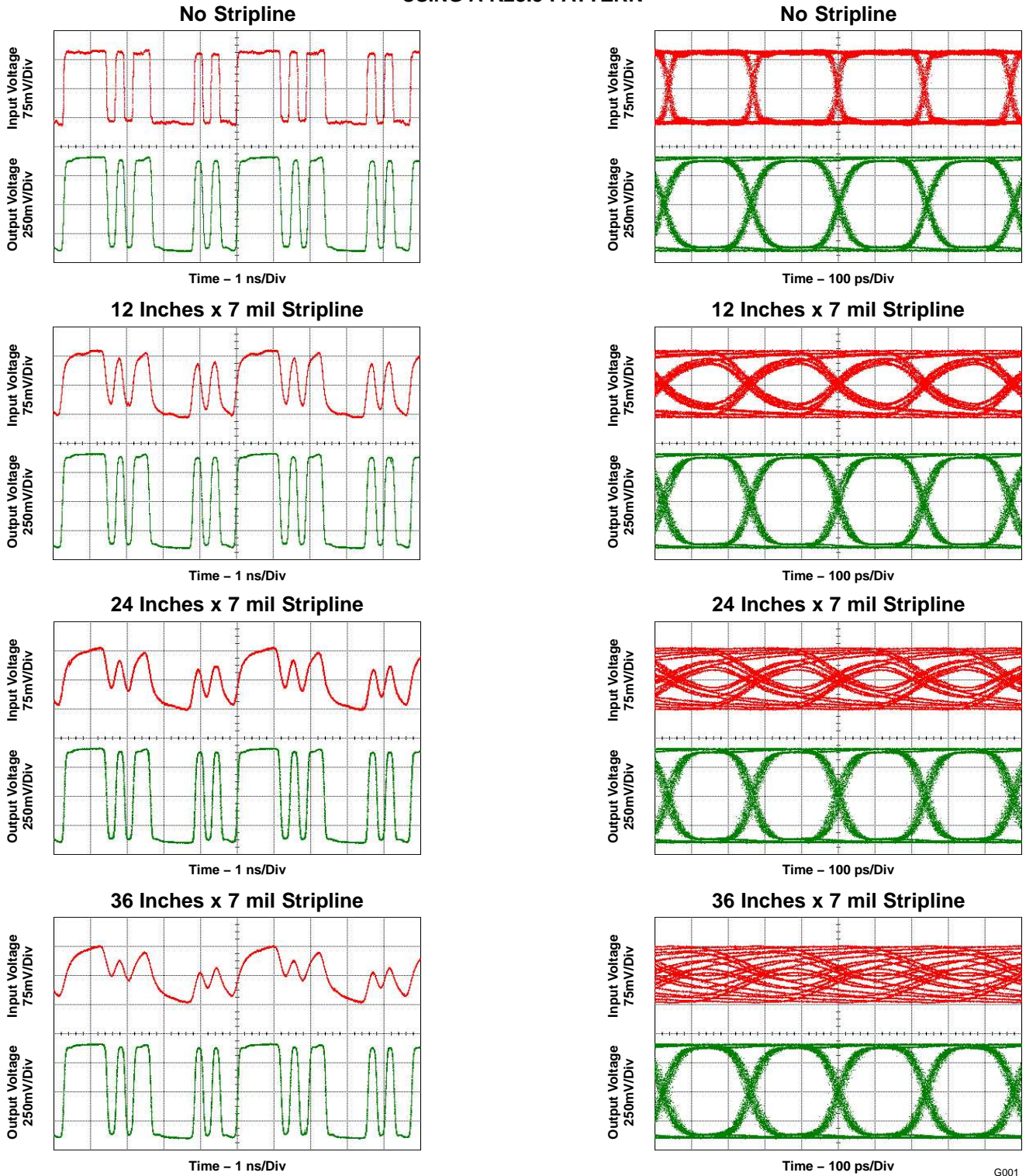
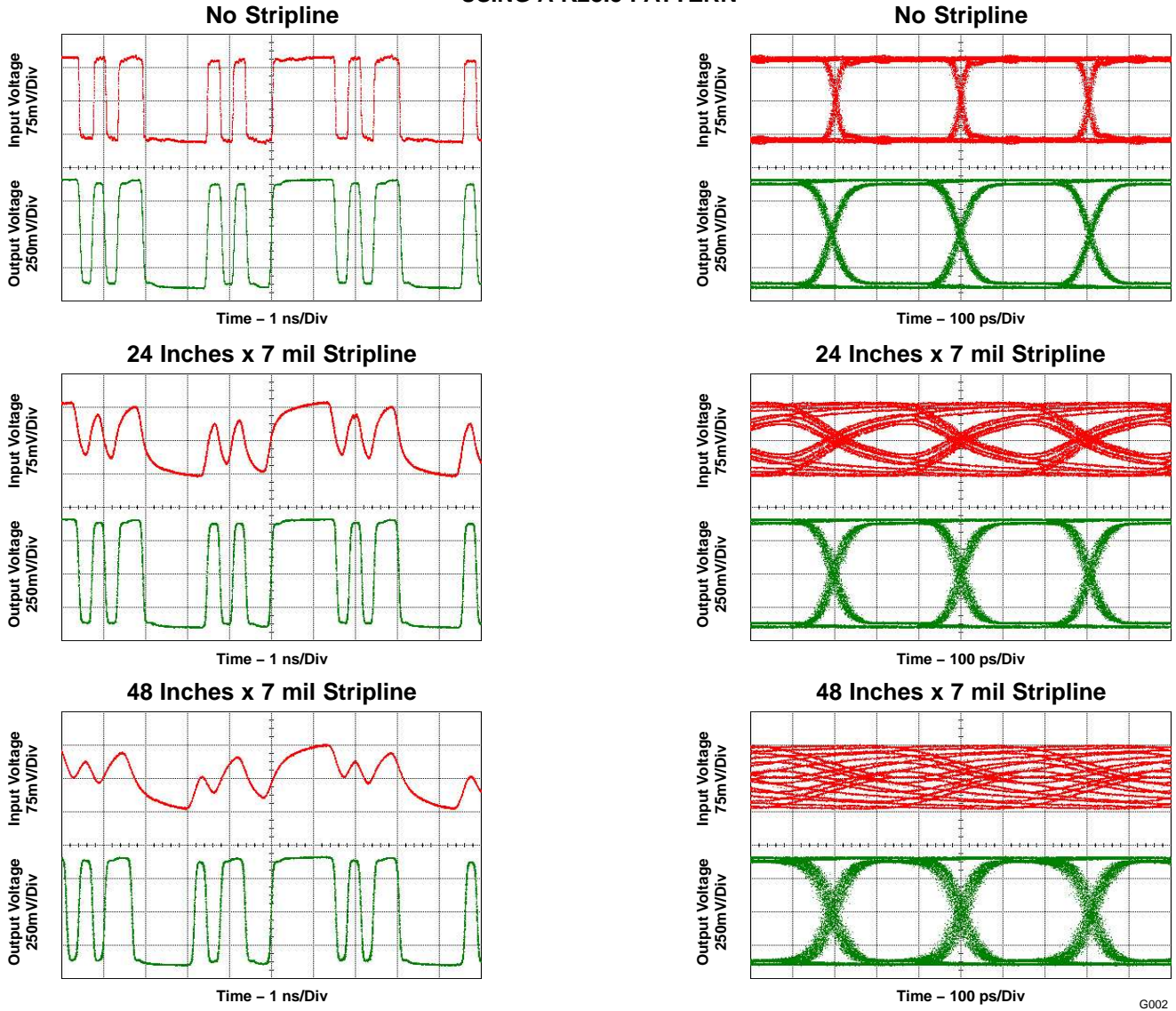

Figure 4. Equalizer Input and Output Signals With Different Interconnect Lines Patterns

TYPICAL CHARACTERISTICS (continued)

Typical operating condition is at $V_{CC} = 3.3\text{ V}$ and $T_A = 25^\circ\text{C}$ (unless otherwise noted).

DIFFERENTIAL EQUALIZER INPUT SIGNAL (TOP) AND OUTPUT SIGNAL (BOTTOM) AT 3.3 GBPS USING A K28.5 PATTERN



G002

Figure 5. Equalizer Input and Output Signals With Different Interconnect Lines and Data

TYPICAL CHARACTERISTICS (continued)

Typical operating condition is at $V_{CC} = 3.3\text{ V}$ and $T_A = 25^\circ\text{C}$ (unless otherwise noted).

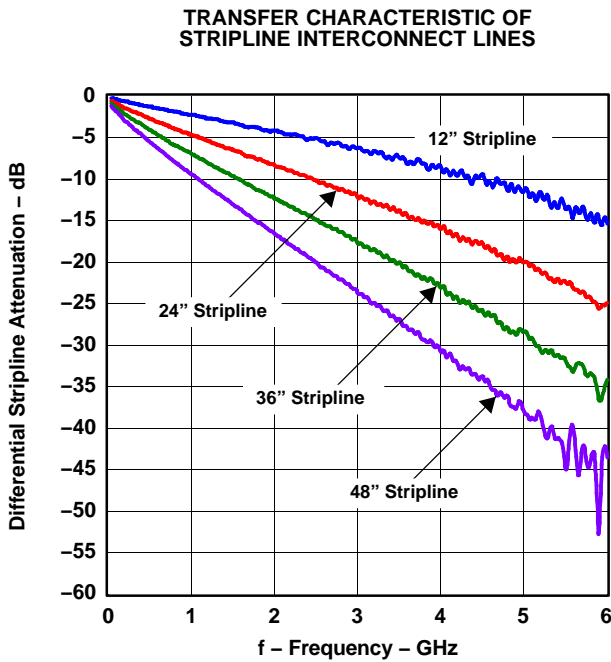

Figure 6.

G003

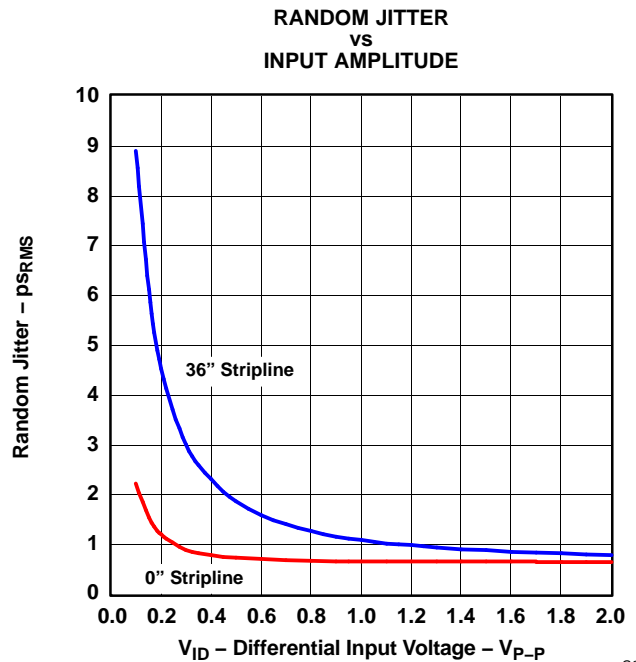

Figure 7.

G004

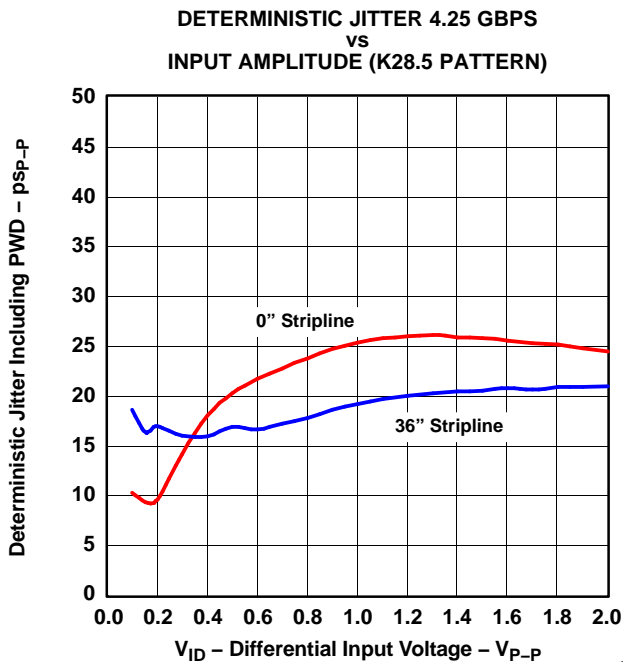

Figure 8.

G005

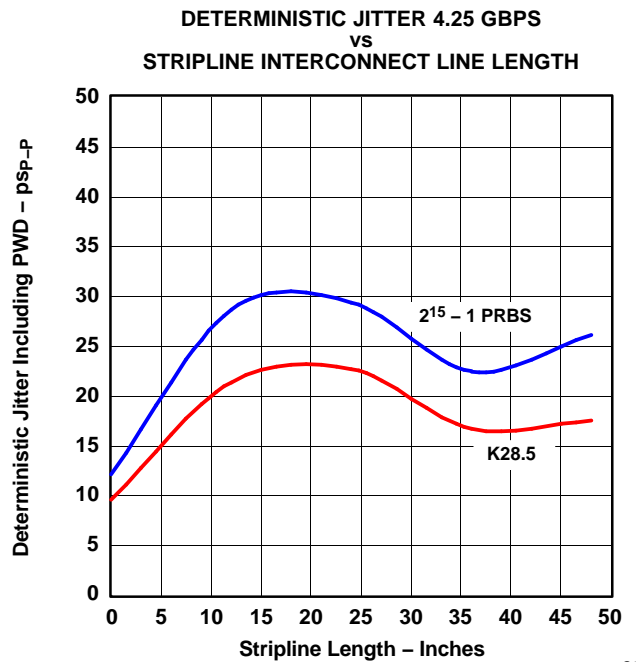

Figure 9.

G006

TYPICAL CHARACTERISTICS (continued)

Typical operating condition is at $V_{CC} = 3.3\text{ V}$ and $T_A = 25^\circ\text{C}$ (unless otherwise noted).

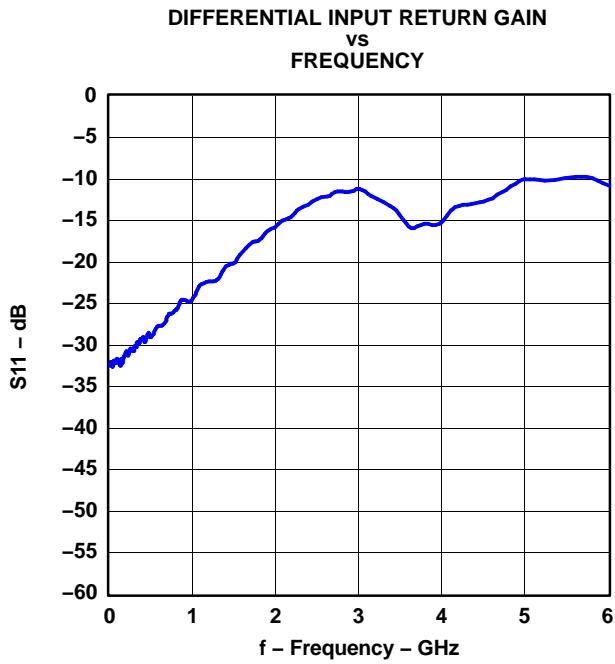

Figure 10.

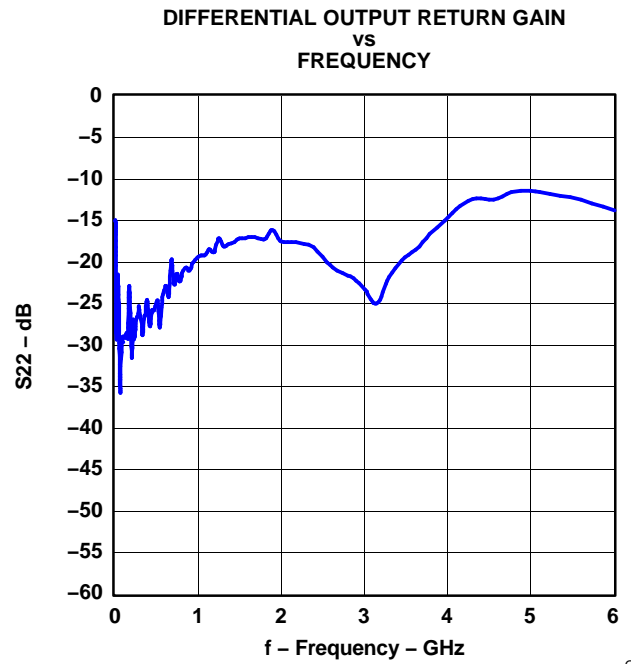

Figure 11.

PACKAGING INFORMATION

Orderable Device	Status (1)	Package Type	Package Drawing	Pins	Package Qty	Eco Plan (2)	Lead/Ball Finish (6)	MSL Peak Temp (3)	Op Temp (°C)	Device Marking (4/5)	Samples
TLK4211EARGTR	OBSOLETE	QFN	RGT	16		TBD	Call TI	Call TI	-40 to 85	421E	
TLK4211EARGTRG4	OBSOLETE	QFN	RGT	16		TBD	Call TI	Call TI	-40 to 85		
TLK4211EARGTT	NRND	QFN	RGT	16	250	Green (RoHS & no Sb/Br)	CU NIPDAU	Level-2-260C-1 YEAR	-40 to 85	421E	

(1) The marketing status values are defined as follows:

ACTIVE: Product device recommended for new designs.

LIFEBUY: TI has announced that the device will be discontinued, and a lifetime-buy period is in effect.

NRND: Not recommended for new designs. Device is in production to support existing customers, but TI does not recommend using this part in a new design.

PREVIEW: Device has been announced but is not in production. Samples may or may not be available.

OBSOLETE: TI has discontinued the production of the device.

(2) Eco Plan - The planned eco-friendly classification: Pb-Free (RoHS), Pb-Free (RoHS Exempt), or Green (RoHS & no Sb/Br) - please check <http://www.ti.com/productcontent> for the latest availability information and additional product content details.

TBD: The Pb-Free/Green conversion plan has not been defined.

Pb-Free (RoHS): TI's terms "Lead-Free" or "Pb-Free" mean semiconductor products that are compatible with the current RoHS requirements for all 6 substances, including the requirement that lead not exceed 0.1% by weight in homogeneous materials. Where designed to be soldered at high temperatures, TI Pb-Free products are suitable for use in specified lead-free processes.

Pb-Free (RoHS Exempt): This component has a RoHS exemption for either 1) lead-based flip-chip solder bumps used between the die and package, or 2) lead-based die adhesive used between the die and leadframe. The component is otherwise considered Pb-Free (RoHS compatible) as defined above.

Green (RoHS & no Sb/Br): TI defines "Green" to mean Pb-Free (RoHS compatible), and free of Bromine (Br) and Antimony (Sb) based flame retardants (Br or Sb do not exceed 0.1% by weight in homogeneous material)

(3) MSL, Peak Temp. - The Moisture Sensitivity Level rating according to the JEDEC industry standard classifications, and peak solder temperature.

(4) There may be additional marking, which relates to the logo, the lot trace code information, or the environmental category on the device.

(5) Multiple Device Markings will be inside parentheses. Only one Device Marking contained in parentheses and separated by a "~" will appear on a device. If a line is indented then it is a continuation of the previous line and the two combined represent the entire Device Marking for that device.

(6) Lead/Ball Finish - Orderable Devices may have multiple material finish options. Finish options are separated by a vertical ruled line. Lead/Ball Finish values may wrap to two lines if the finish value exceeds the maximum column width.

Important Information and Disclaimer: The information provided on this page represents TI's knowledge and belief as of the date that it is provided. TI bases its knowledge and belief on information provided by third parties, and makes no representation or warranty as to the accuracy of such information. Efforts are underway to better integrate information from third parties. TI has taken and continues to take reasonable steps to provide representative and accurate information but may not have conducted destructive testing or chemical analysis on incoming materials and chemicals. TI and TI suppliers consider certain information to be proprietary, and thus CAS numbers and other limited information may not be available for release.

In no event shall TI's liability arising out of such information exceed the total purchase price of the TI part(s) at issue in this document sold by TI to Customer on an annual basis.

TAPE AND REEL INFORMATION



QUADRANT ASSIGNMENTS FOR PIN 1 ORIENTATION IN TAPE



*All dimensions are nominal

Device	Package Type	Package Drawing	Pins	SPQ	Reel Diameter (mm)	Reel Width W1 (mm)	A0 (mm)	B0 (mm)	K0 (mm)	P1 (mm)	W (mm)	Pin1 Quadrant
TLK4211EARGTT	QFN	RGT	16	250	180.0	12.4	3.3	3.3	1.1	8.0	12.0	Q2

TAPE AND REEL BOX DIMENSIONS

*All dimensions are nominal

Device	Package Type	Package Drawing	Pins	SPQ	Length (mm)	Width (mm)	Height (mm)
TLK4211EARGTT	QFN	RGT	16	250	338.1	338.1	20.6

RGT (S-PVQFN-N16)

PLASTIC QUAD FLATPACK NO-LEAD

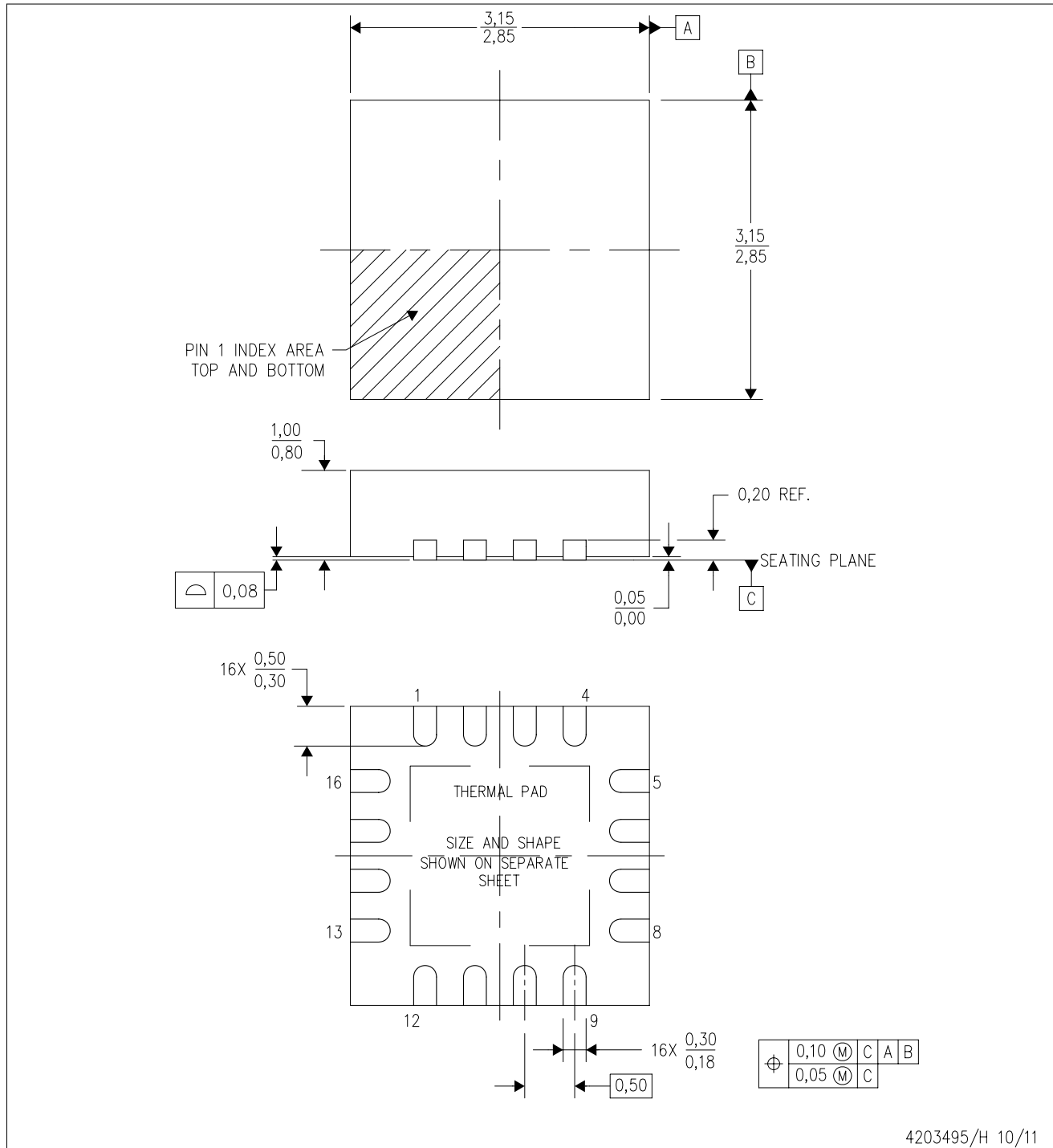

- NOTES:
- All linear dimensions are in millimeters. Dimensioning and tolerancing per ASME Y14.5M-1994.
 - This drawing is subject to change without notice.
 - Quad Flatpack, No-leads (QFN) package configuration.
 - The package thermal pad must be soldered to the board for thermal and mechanical performance.
 - See the additional figure in the Product Data Sheet for details regarding the exposed thermal pad features and dimensions.
 - Falls within JEDEC MO-220.

THERMAL PAD MECHANICAL DATA

RGT (S-PVQFN-N16)

PLASTIC QUAD FLATPACK NO-LEAD

THERMAL INFORMATION

This package incorporates an exposed thermal pad that is designed to be attached directly to an external heatsink. The thermal pad must be soldered directly to the printed circuit board (PCB). After soldering, the PCB can be used as a heatsink. In addition, through the use of thermal vias, the thermal pad can be attached directly to the appropriate copper plane shown in the electrical schematic for the device, or alternatively, can be attached to a special heatsink structure designed into the PCB. This design optimizes the heat transfer from the integrated circuit (IC).

For information on the Quad Flatpack No-Lead (QFN) package and its advantages, refer to Application Report, QFN/SON PCB Attachment, Texas Instruments Literature No. SLUA271. This document is available at www.ti.com.

The exposed thermal pad dimensions for this package are shown in the following illustration.

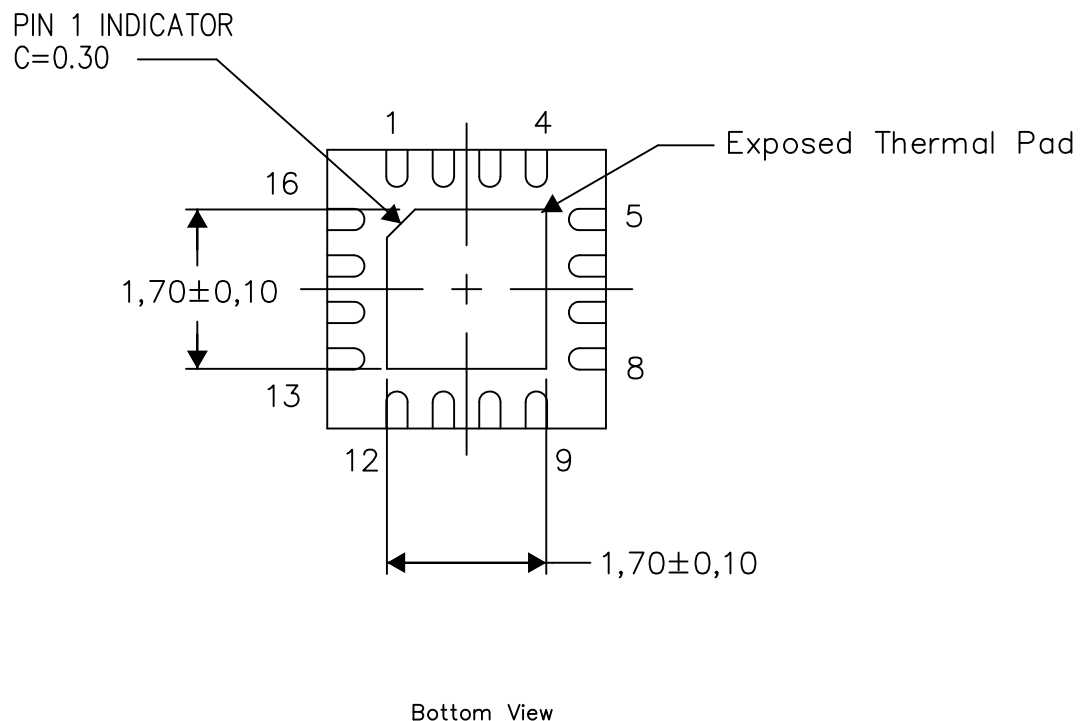

Exposed Thermal Pad Dimensions

4206349-4/U 09/13

NOTE: All linear dimensions are in millimeters

RGT (S-PVQFN-N16)

PLASTIC QUAD FLATPACK NO-LEAD

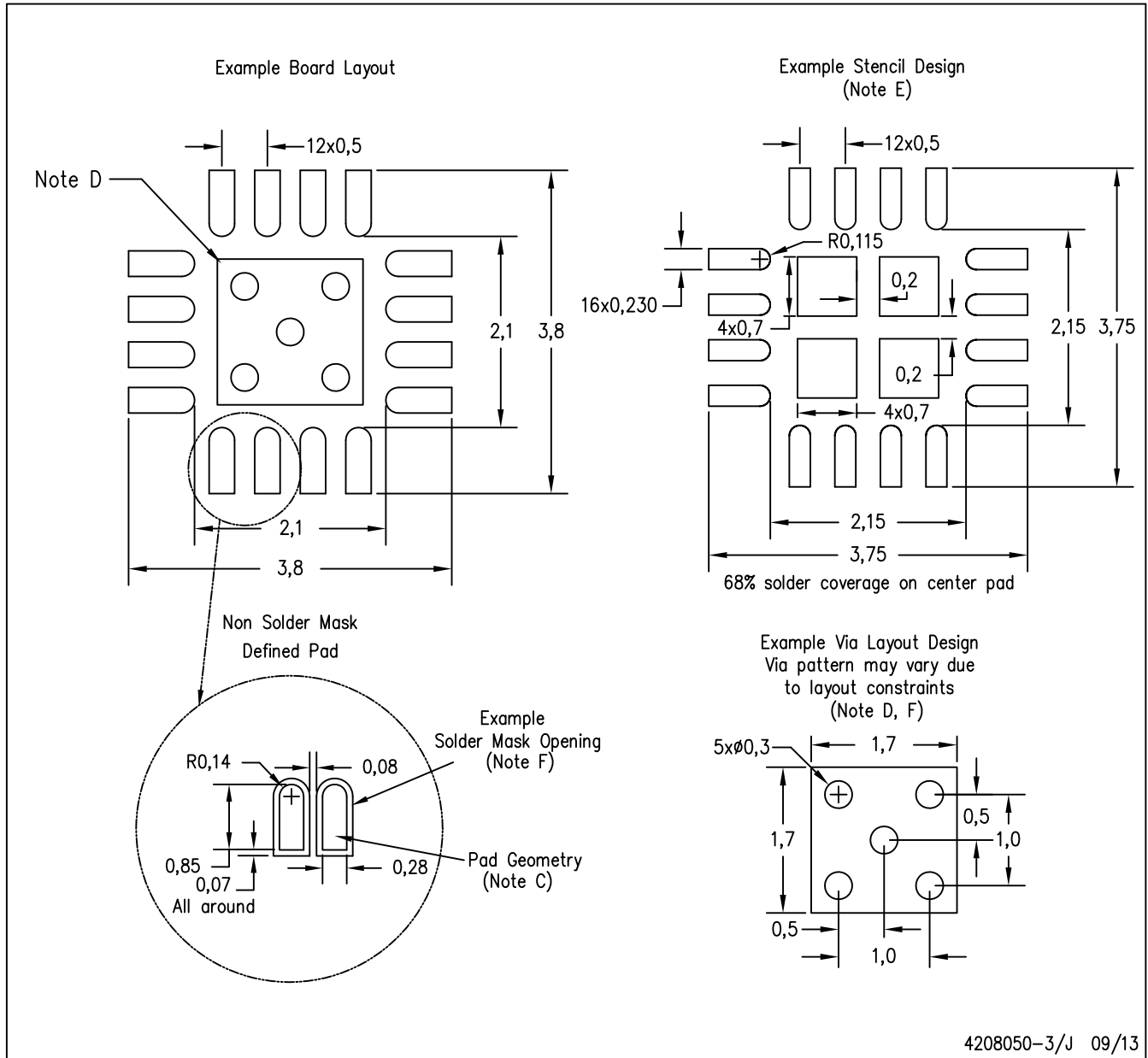

- NOTES:
- A. All linear dimensions are in millimeters.
 - B. This drawing is subject to change without notice.
 - C. Publication IPC-7351 is recommended for alternate designs.
 - D. This package is designed to be soldered to a thermal pad on the board. Refer to Application Note, QFN/SON PCB Attachment, Texas Instruments Literature No. SLUA271, and also the Product Data Sheets for specific thermal information, via requirements, and recommended board layout. These documents are available at www.ti.com <<http://www.ti.com>>.
 - E. Laser cutting apertures with trapezoidal walls and also rounding corners will offer better paste release. Customers should contact their board assembly site for stencil design recommendations. Refer to IPC 7525 for stencil design considerations.
 - F. Customers should contact their board fabrication site for minimum solder mask web tolerances between signal pads.

IMPORTANT NOTICE

Texas Instruments Incorporated and its subsidiaries (TI) reserve the right to make corrections, enhancements, improvements and other changes to its semiconductor products and services per JESD46, latest issue, and to discontinue any product or service per JESD48, latest issue. Buyers should obtain the latest relevant information before placing orders and should verify that such information is current and complete. All semiconductor products (also referred to herein as "components") are sold subject to TI's terms and conditions of sale supplied at the time of order acknowledgment.

TI warrants performance of its components to the specifications applicable at the time of sale, in accordance with the warranty in TI's terms and conditions of sale of semiconductor products. Testing and other quality control techniques are used to the extent TI deems necessary to support this warranty. Except where mandated by applicable law, testing of all parameters of each component is not necessarily performed.

TI assumes no liability for applications assistance or the design of Buyers' products. Buyers are responsible for their products and applications using TI components. To minimize the risks associated with Buyers' products and applications, Buyers should provide adequate design and operating safeguards.

TI does not warrant or represent that any license, either express or implied, is granted under any patent right, copyright, mask work right, or other intellectual property right relating to any combination, machine, or process in which TI components or services are used. Information published by TI regarding third-party products or services does not constitute a license to use such products or services or a warranty or endorsement thereof. Use of such information may require a license from a third party under the patents or other intellectual property of the third party, or a license from TI under the patents or other intellectual property of TI.

Reproduction of significant portions of TI information in TI data books or data sheets is permissible only if reproduction is without alteration and is accompanied by all associated warranties, conditions, limitations, and notices. TI is not responsible or liable for such altered documentation. Information of third parties may be subject to additional restrictions.

Resale of TI components or services with statements different from or beyond the parameters stated by TI for that component or service voids all express and any implied warranties for the associated TI component or service and is an unfair and deceptive business practice. TI is not responsible or liable for any such statements.

Buyer acknowledges and agrees that it is solely responsible for compliance with all legal, regulatory and safety-related requirements concerning its products, and any use of TI components in its applications, notwithstanding any applications-related information or support that may be provided by TI. Buyer represents and agrees that it has all the necessary expertise to create and implement safeguards which anticipate dangerous consequences of failures, monitor failures and their consequences, lessen the likelihood of failures that might cause harm and take appropriate remedial actions. Buyer will fully indemnify TI and its representatives against any damages arising out of the use of any TI components in safety-critical applications.

In some cases, TI components may be promoted specifically to facilitate safety-related applications. With such components, TI's goal is to help enable customers to design and create their own end-product solutions that meet applicable functional safety standards and requirements. Nonetheless, such components are subject to these terms.

No TI components are authorized for use in FDA Class III (or similar life-critical medical equipment) unless authorized officers of the parties have executed a special agreement specifically governing such use.

Only those TI components which TI has specifically designated as military grade or "enhanced plastic" are designed and intended for use in military/aerospace applications or environments. Buyer acknowledges and agrees that any military or aerospace use of TI components which have **not** been so designated is solely at the Buyer's risk, and that Buyer is solely responsible for compliance with all legal and regulatory requirements in connection with such use.

TI has specifically designated certain components as meeting ISO/TS16949 requirements, mainly for automotive use. In any case of use of non-designated products, TI will not be responsible for any failure to meet ISO/TS16949.

Products

Audio	www.ti.com/audio
Amplifiers	amplifier.ti.com
Data Converters	dataconverter.ti.com
DLP® Products	www.dlp.com
DSP	dsp.ti.com
Clocks and Timers	www.ti.com/clocks
Interface	interface.ti.com
Logic	logic.ti.com
Power Mgmt	power.ti.com
Microcontrollers	microcontroller.ti.com
RFID	www.ti-rfid.com
OMAP Applications Processors	www.ti.com/omap
Wireless Connectivity	www.ti.com/wirelessconnectivity

Applications

Automotive and Transportation	www.ti.com/automotive
Communications and Telecom	www.ti.com/communications
Computers and Peripherals	www.ti.com/computers
Consumer Electronics	www.ti.com/consumer-apps
Energy and Lighting	www.ti.com/energy
Industrial	www.ti.com/industrial
Medical	www.ti.com/medical
Security	www.ti.com/security
Space, Avionics and Defense	www.ti.com/space-avionics-defense
Video and Imaging	www.ti.com/video

TI E2E Community

e2e.ti.com